

EG40-80 SERIES

OFF-GRID SOLAR LED LIGHTING

The EG40 and EG80 are ideal for ...

Streets and roadways, pathways, parks, perimeter lighting and many other general lighting applications

New facilities where:

- access to the electrical grid requires extensive trenching
- grid connection is difficult or impossible
- underground checks and/or permits are costly

Existing facilities where:

- access to the electrical grid requires extensive trenching or environmental disruption
- disruption of site will result in loss of business
- underground wiring / conduit is nearing end of life
- copper theft and vandalism is a concern

The Carmanah Difference:

- Reduced project cost when compared to other solar LED lighting systems: a result of superior uniformity and lumen output
- Adaptive lighting allows user to determine how light is applied
- Pole-top integrated design for easy installation and theft prevention
- Recyclable battery & components
- Reliable, year-round performance

Capabilities:

- High-efficiency LED light fixture
- Adaptive lighting (dimming capabilities)
- Standard IES distributions (Type II, III, IV, V) and flood
- Principal roads, secondary residential roads and rural roads classification
- 3000K - 5000K and 5000K - 6000K colour temperature options

LED Fixtures

The EG40-80 series features a high performance LED fixture. With superior uniformity and light performance, Carmanah solar lighting systems illuminate a given area with fewer systems than other solar solutions, providing significant savings in overall project cost.



Carmanah EG80 Off-Grid Solar LED Lighting System

Adaptive Lighting

Adaptive lighting allows for different light levels during the course of the night, based on vehicle and pedestrian activity. A choice of operating profiles permits the light to be dimmed or turned off completely when facility usage is reduced.

By dimming or turning the system off when light is not needed energy is conserved and light levels during peak hours are maximized. This allows for brighter illumination, smaller system size and lower system cost.

Energy Management System

The Energy Management System (EMS) is a critical part of the EG40 and EG80 system. The EMS ensures bright, reliable light output and healthy, high-functioning lighting systems for years of autonomous operation.

The EMS provides:

- Efficient transfer & dynamic management of energy
- Flexible dimming functions
- Smaller sized systems with greater lumen output

REPRESENTED IN YOUR REGION BY:



EG40-80 SERIES

OFF-GRID SOLAR LED LIGHTING



Carmanah EG40 Off-Grid Solar LED Lighting System

SOLAR ENGINE	EG40	EG80
EPA*	0.23 m ² (2.6 ft ²)	0.34 m ² (3.7 ft ²)
APA	0.18 m ² (2.0 ft ²)	0.26 m ² (2.8 ft ²)
Weight (without batteries)	16.7 kg (36.7 lb)	18.6 kg (41.0 lb)
Weight (with batteries)	34.8 kg (76.7 lb)	47.7 kg (105.0 lb)
Dimension A	66.5 cm (25.8 in)	121 cm (47.6 in)
Dimension B	54.0 cm (21.3 in)	54.0 cm (21.3 in)
BATTERIES		
Type	Deep cycle absorbed glass mat (AGM) or gel	
FIXTURE		
LED	High-efficiency light fixture	
MOUNTING		
Solar Engine	Top of pole, round tenon 8.9 cm (3.5 in) outer diameter	
Fixture	Mounts to horizontal tenon 4.25 cm (1.675 in) or 6 cm (2.375 in) outer diameter	
Wind Load Rating	209 kph (130 mph)**	
ENERGY MANAGEMENT SYSTEM (EMS)		
Optional Operating Profiles	Dusk-to-dawn Evening/morning mode Standard controller	
Day/night transitioning	Via solar panels	
Status Indicators	Battery connection, low/high voltage disconnect, dimming	
PHOTOMETRICS		
Fixture Efficacy	Minimum 85 lm/W	
IES Light Distributions	Type II, Type III, Type IV, Type V (backlight control available) and Flood	
Other	International Dark-Sky Association (IDA) approved, measured for performance using IESNA standards including IES BUG rating system	
Photometry	Certified photometry per IESNA LM-79-2008 & LM-80-2008	
Typical Applications	Streets, roadways, parking lots, general site lighting	
Photometric performance depends on the solar environment of location and specified operating profile. Contact a Carmanah representative for exact lumen output and specifications for your application.		
CERTIFICATIONS		
CE 2004-108-CE, EN 55015, EN 61547 for emissions and immunity IP 68 Energy Management System (EMS)		
ACCESSORIES		
Remote control		

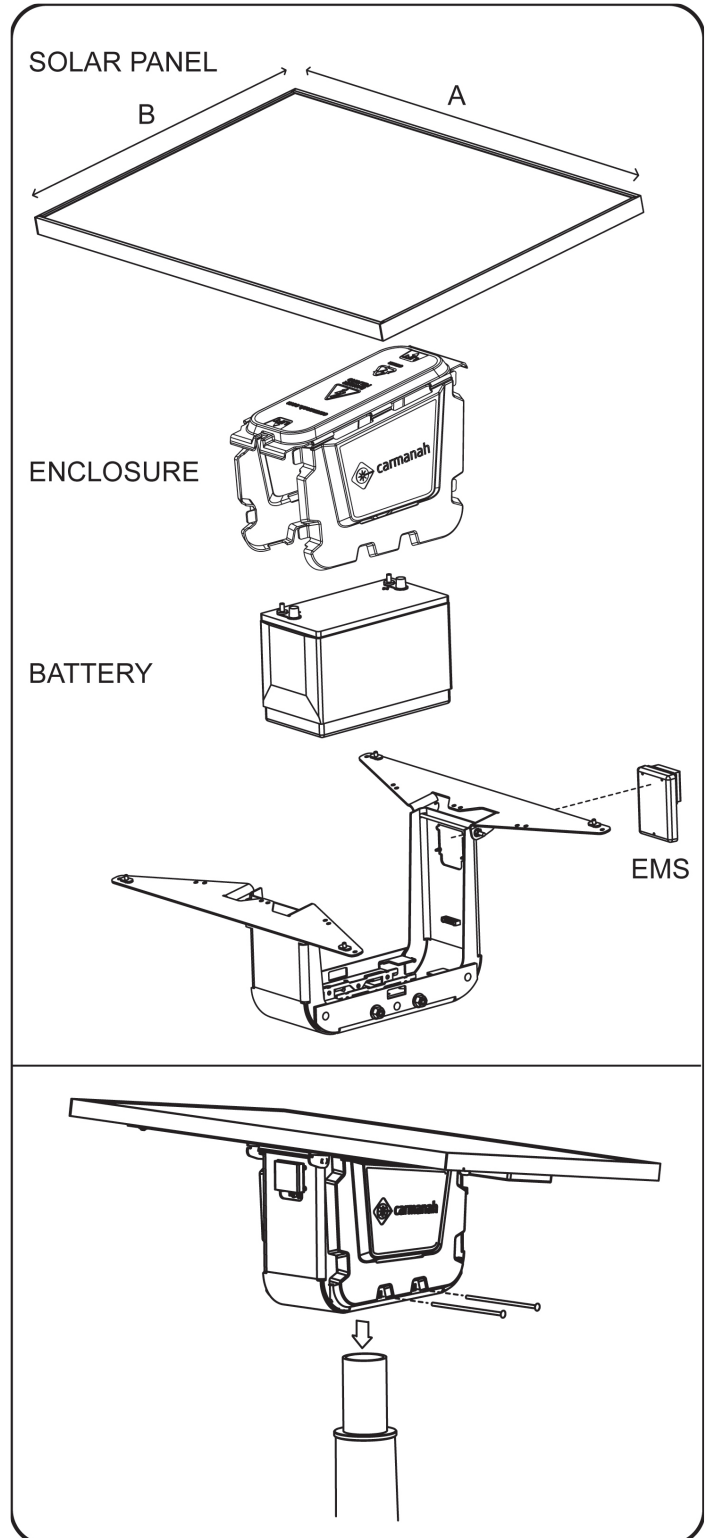

* Effective Projected Area (EPA) calculated as the Actual Projected Area (APA) multiplied by a drag coefficient of 1.3. EPA of engine only; does not include fixture EPA.
 ** 3 second gust as per AASHTO 2001
 Note: specifications subject to change without notice